

EmbryoSlide+ ic8 dishes

First issue 2022.11.03, revised 2023.07.07

English

Scope of application

The EmbryoSlide+ ic8 dish is intended for the culture of oocytes and embryos in the EmbryoScope+ or EmbryoScope 8 incubator.

Contraindications

None known.

Intended users

Embryologists, other laboratory personnel and clinic staff at IVF clinics trained by Vitrolife A/S-certified instructors.

Intended patient group

Patients undergoing infertility treatment.

Clinical benefits

- Improved embryo development
- Improved implantation/pregnancy rate
- Reduced pregnancy loss rate.

Limitations and restrictions on use

The EmbryoSlide+ ic8 dish is only intended for use in the EmbryoScope+ and EmbryoScope 8 incubators and must be handled by trained personnel according to the instructions in this insert. Any serious incident that has occurred in relation to the dish should be reported to Vitrolife and to the competent authority of the Member State in which the user is established.

The EmbryoSlide+ ic8 dishes and lids are sterile. The pouches must only be opened in a sterile laminar flow hood, and the dish must be covered by the lid when in use.

Warnings and precautions

WARNINGS

The EmbryoSlide+ ic8 dish is intended for single use only and MAY NOT be re-used. Any attempt by the user to clean and re-sterilise the dish may result in contamination with microorganisms or other risks of device failure.

To avoid contamination with microorganisms, always place the dish in a sterile laminar flow hood while loading and generally handling the dish.

Always label the dish appropriately and validate the label when the embryo is transferred either to a new device or to the patient.

PRECAUTIONS

Do not use the rinsing wells for incubating embryos as no images are acquired from these wells.

The reservoir and rinsing wells MUST always be covered by a confluent oil layer of 1.6 ml of IVF-grade oil. This prevents the medium from evaporating during incubation.

Evaporation of the medium can change osmolality, which may affect embryo development.

Always place the dish in a sterile laminar flow hood while loading it. Take care while loading and handling the dish to reduce the risk of spilling any oil or medium.

If ANY oil or medium is accidentally spilled from the dish while it is loaded or handled, the embryos MUST be transferred to a new dish to prevent them from being adversely affected by the spillage.

In case any oil is spilled on the dish outside of the reservoir, gently wipe off the oil by using a lint-free tissue paper. If any oil is present on the lid, the lid must be replaced.

If any bubbles are present in the well or oil layer after preparation, they may block the camera light and compromise image quality. In rare cases, bubbles may dislodge the embryo from the bottom of the microwell.

Any bubbles must be removed carefully and relatively quickly to avoid evaporation of medium.

Take care not to remove any medium when removing the bubbles.

Discard the product according to standard clinical practice for medical hazardous waste when the procedure is finished.

Product description

The EmbryoSlide+ ic8 dish is a single-use sterile dish designed for the culture of embryos in the EmbryoScope+ and EmbryoScope 8 incubators.

The EmbryoSlide+ ic8 dish contains two types of wells: eight culture wells in which the embryos reside during incubation and four rinsing wells that are used for rinsing and handling the embryos. The embryos reside in a central depression – the microwell – inside each culture well. The culture wells are cylindrical and have a diameter of 3.45 mm. The microwells are conic with a curved bottom and have a bottom diameter of 0.28 mm. See the illustration on the last page of this insert for an overview of the dish.

Preparing the dish

Prepare one dish at a time to minimise handling time. Work on a non-heated workbench and use cold medium and oil.

1. Remove the dish from the pouch in a sterile laminar flow hood.
2. Fill all microwells with medium using a micropipette (max. diameter: 200 µm). One filling of the tip will suffice to completely fill all microwells. The tip of the pipette must touch the side of the microwell during filling. Slightly overfill each microwell.
3. Use a standard pipette to immediately fill an additional 20 µl of medium into each well (160 µl in total to fill all eight wells).
4. Fill each rinsing well with max. 30 µl and min. 25 µl of medium.
5. Load 1.6 ml of oil certified for IVF into the reservoir. Make sure that all culture wells and rinsing wells are covered with a confluent oil layer. Add an additional amount of oil for each well or reservoir not filled with medium.
6. Push up any large bubbles with a micropipette and then remove them.
7. Cover the dish with the lid and equilibrate it overnight.
8. Identify and remove any bubbles under a stereo microscope.
9. Place the barcode label on the dedicated label tab on the dish. The barcode must be placed so that it is possible to read the text on the label when the dish is correctly inserted into the incubator. Make sure that the label is smoothed out as best as possible to avoid wrinkles in the paper. If the barcode is in any way damaged or not smoothly applied, the label cannot be read. In this case, print a new label from the EmbryoViewer software.
10. Load embryos into the centre of the microwells using a micropipette.
11. Place the dish in the incubator.

Product name

Culture dishes.

Product model and specification

Model and specification: 16454, EmbryoSlide+ ic8 dish.

Product registration certificate number/product technical requirement number

Product registration certificate number:
国械注进 20202180348

Product technical requirement number:
国械注进 20202180348

Product features

Sterile	SAL 10 ⁻⁶
Bacterial endotoxin (LAL experiment) [EU/item]	< 20
Mouse in-vitro embryo test (1-cytoplasm mouse embryo) [expanded blastocyst percentage on the fifth day]	≥ 80%

All products include the quality inspection analysis report for the corresponding batch number.

Product main structure and composition

This product is made of uncoated polystyrene.

Manufacturing date, expiry date and storage and transportation conditions

Manufacturing date: see the product label.
Expiry date: see the product label.
Storage conditions: store at room temperature.
Transportation conditions: transport at room temperature.

Registration applicant/manufacturing organisation, domicile, manufacturing address, production licence number and contact information

Name: Vitrolife A/S
Domicile and manufacturing address: Jens Juuls Vej 20, 8260 Viby J, Denmark
Production licence number: CVR (DK) 27406793
Telephone: +45 7221 7900
Fax: +45 7221 7901

Agent/after-sales service company name, address and contact information

Name: Vitrolife (Beijing) Medical Device Co., Ltd.
Address: Room 2006, 20th (17) Floor, Building No. 3, No. 6 Futong East Street, Chaoyang District, Beijing, China
Zip code: 100102
Telephone: +86 10 64036613
Fax: +86 10 64036613
E-mail: support.asia@vitrolife.com
www.vitrolife.com

中文

适用范围

EmbryoSlide+ ic8 适用于时差培养箱（型号：ES-P1）和时差培养箱（型号：ES8）中卵母细胞和胚胎的培养。

禁忌症

未知。

目标用户

接受 Vitrolife A/S 认证讲师培训的 IVF 诊所的胚胎学家、其他实验室人员和诊所工作人员。

目标患者群

接受生育治疗的患者。

临床获益

- 改善胚胎发育
- 提高着床/妊娠率
- 降低流产率。

限制条件和使用限制

EmbryoSlide+ ic8 培养皿只能用于 EmbryoScope+ 和 EmbryoScope 8 培养箱、并且必须由经过培训的人员根据本说明书中的说明进行操作。任何与培养皿有关的严重事故都应报告给 Vitrolife 和用户所在成员国的主管部门。

EmbryoSlide+ ic8 培养皿和盖子是无菌的。包装袋只能在无菌洁净层流罩内打开、且使用时应盖好培养皿盖。

警告和预防措施

警告

EmbryoSlide+ ic8 培养皿仅供一次性使用、不得重复使用。若使用者试图清洁或重新对培养皿消毒、可能会引发微生物污染或其他设备故障风险。

为避免微生物污染、在加载培养皿和对其进行一般操作时、始终将培养皿置于无菌洁净层流罩内。

当胚胎转移到新设备或患者体内时、请始终将培养皿上的标签加贴妥善并进行确认。

预防措施

由于从冲洗孔中无法采集图像、请勿使用此类孔孵育胚胎。

储液槽和冲洗孔必须始终使用 1.6 ml IVF 级油的培养油层覆盖。如此可防止培养基在培养过程中挥发。

培养基的挥发将改变渗透压、从而影响胚胎发育。

在加载培养皿时、始终将其置于无菌洁净层流罩内。在加载和操作培养皿时、注意降低一切油或培养基溢出的风险。

若在加载或操作培养皿时任何油或培养基不慎溢出培养皿、必须将胚胎转移到新的培养皿中、以防止胚胎受到溢出物的不良影响。

若有油溢出到储液槽外部的培养皿上、请用无绒纸巾轻轻擦除油污。若培养皿盖上沾有油污、则须更换盖子。

如果在准备好培养皿后发现孔内或油层中存在气泡、则这些气泡可能会阻挡相机光线、影响图像质量。在极少数情况下、气泡可能会将胚胎从微孔底部挤出。

必须小心且较快速地去掉所有气泡、以避免培养基蒸发。

注意不要在去除气泡时移走任何培养基。

完成该程序后、根据医疗危险废弃物的标准临床惯例丢弃该产品。

产品说明

EmbryoSlide+ ic8 培养皿是一种一次性使用的无菌培养皿、用于在 EmbryoScope+ 和 EmbryoScope 8 培养箱中培养胚胎。

EmbryoSlide+ ic8 培养皿包含两类孔：八个培养孔（胚胎在培养期间放置其中）和四个冲洗孔（用于冲洗和处理胚胎）。胚胎位于每个培养孔内的中心凹陷处（微孔）。培养孔为圆柱形、直径为 3.45 mm。微孔为圆锥形、底部为弧形且直径为 0.28 mm。有关培养皿的概述、请参阅本说明书最后一页的相关说明。

准备培养皿

一次准备一个培养皿、以尽量减少操作时间。在非加热工作台上操作、使用冷培养基和油。

1. 在无菌洁净层流罩内将培养皿从包装袋中取出。
2. 使用微量移液管（最大直径：200 µm）将所有微孔填满培养基。一个吸头的液体就足以填满所有微孔。在填充期间、移液管的尖端必须接触到微孔的侧面。使填充液量稍微超出微孔容量。
3. 使用标准移液管立即向各个培养孔注入另外 20 µl 培养基（总共 160 µl、可填充所有八个培养孔）。
4. 为每个冲洗孔注入 25 µl-30 µl 培养基。
5. 将 1.6 ml 经过认证的适用于 IVF 的油加载到储液槽中。确保所有培养孔和冲洗孔全部都被油层覆盖。为每个未填满培养基的培养孔或储液槽添加额外的油。
6. 用微量移液管将所有大气泡推至上方后去除。
7. 用盖子盖住培养皿并放置一晚、以待平衡。
8. 在立体显微镜下识别并去除所有气泡。
9. 将条形码标签贴在培养皿的指定位置。必须放置条形码、以便在将培养皿正确放入培养箱中时读取标签上的文字。确保标签尽可能平整、避免纸张起皱。如果条形码被以任何方式损坏或粘贴不平整、则无法读取标签。在此情况下、请从 EmbryoViewer 软件打印新标签。
10. 使用微量移液管将胚胎装入微孔的中心。
11. 将培养皿放在培养箱中。

产品名称

胚胎培养皿。

产品型号及规格

型号、规格：16454、EmbryoSlide+ ic8 dish。

产品注册证及技术要求编号

产品注册证编号：国械注进 20202180348

产品技术要求编号：国械注进 20202180348

产品性能

无菌	SAL 10 ⁻⁶
细菌内毒素（LAL 实验）[EU/件]	< 20
体外鼠胚试验（1-细胞鼠胚）[第 5 天扩张囊胚%]	≥ 80%

随货提供的每个批号的质量检验分析报告。

产品主要结构组成

本产品由聚苯乙烯制造、无涂层。

产品生产日期、失效日期及储存、运输条件

生产日期：见标签。

失效日期：见标签。

储存条件：常温储存。

运输条件：常温运输。

注册申请人/生产企业、住所、生产地址、生产许可证编号和联系方式

名称：Vitrolife A/S 瑞利芙（丹麦）有限公司

住所、生产地址：Jens Juuls Vej 20、8260 Viby J、Denmark

生产许可证编号：CVR (DK) 27406793

电话：+45 7221 7900

传真：+45 7221 7901

代理人/售后服务单位名称、住所和联系方式

名称：瑞利芙（北京）医疗器械有限公司

住所：北京市朝阳区阜通东大街 6 号院 3 号楼 20 层(17)2006 室













邮编：100102

电话：+86 10 64036613

传真：+86 10 64036613

E-mail: support.asia@vitrolife.com

www.vitrolife.com

Symbol	Title	Description	描述
	Catalogue number ISO 15223-1:2021 5.1.6	Indicates the manufacturer's catalogue number so that the medical device can be identified.	表示制造商的目录编号、以便识别医疗设备。
	Batch code ISO 15223-1:2021 5.1.5	Indicates the manufacturer's batch code so that the batch or lot can be identified.	表示制造商的批次代码、以便识别批次。
	Use by date ISO 15223-1:2021 5.1.4	Indicates the date after which the medical device is not to be used.	表示不能再使用该医疗设备的日期。
	Do not re-use ISO 15223-1:2021 5.4.2	Indicates a medical device that is intended for one use or for use on a single patient during a single procedure.	表示某个医疗设备为一次性使用、或在一个手术中单独用于某个患者。
	Do not use if packaging is damaged ISO 15223-1:2021 5.2.8	Indicates a device that should not be used if the package has been damaged or opened.	表示某个医疗设备如果包装损坏或打开、则不能使用。
	CE mark	Declaration by the manufacturer that the device meets all applicable requirements in the Medical Device Regulation (EU) 2017/745.	制造商声明该设备符合医疗器械法规（欧盟）2017/745 中的所有适用要求。
	Sterilised using irradiation ISO 15223-1:2021 5.2.4	Indicates a medical device that has been sterilised using irradiation.	表示医疗设备已辐射消毒。
	Consult the instructions for use ISO 15223-1:2021 5.4.3	Indicates the need for the user to consult the instructions for use.	表示用户需要查阅使用说明。
	Temperature limit ISO 15223-1:2021 5.3.7	Indicates the temperature limits to which the medical device can be safely exposed.	表示医疗设备可以安全暴露的温度范围。
	Manufacturer ISO 15223-1:2021 5.1.1	Indicates the medical device manufacturer.	表示医疗设备的制造商。
	Date of manufacture ISO 15223-1:2021 5.1.3	Indicates the date when the medical device was manufactured.	表示医疗设备的制造日期。
	Medical device ISO 15223-1:2021 5.7.7	Indicates that the device is a medical device.	表示该设备是医疗器械。
	Unique device identifier ISO 15223-1:2021 5.7.10	Indicates a carrier that contains unique device identifier information.	表示包含唯一设备标识信息的载体。

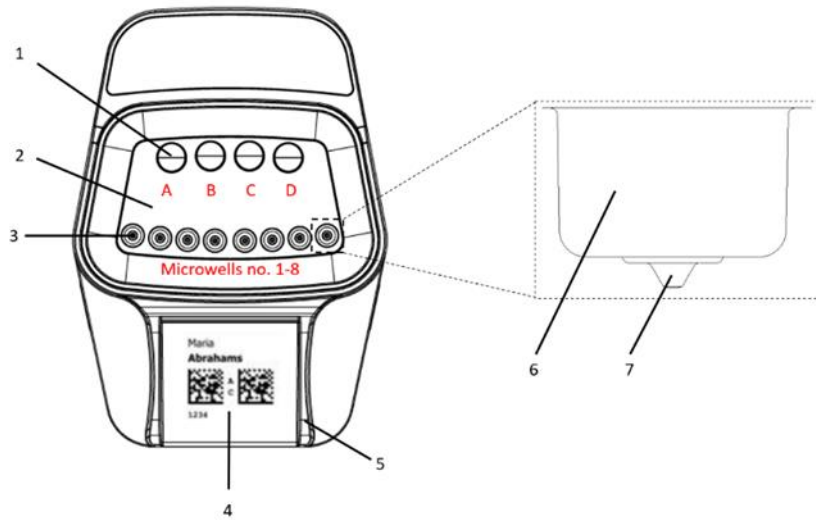

No.	1	2	3	4	5	6	7
English	Rinsing wells	Oil reservoir	Culture wells	Barcode label tab	Handling fins	Well	Microwell
中文	冲洗孔	储油槽	培养孔	条形码标签选项卡	手柄	培养孔	微孔

Technical support

Tel.: +45 7023 0500
 E-mail: support.embryoscope@vitrolife.com
 www.vitrolife.com

 Vitrolife A/S
 Jens Juuls Vej 20
 DK-8260 Viby J
 Tel.: +45 7221 7900

